

SC17FZD Motorised Foldable Monitors

FOLDABLE MONITOR

With its motorised foldable design, the monitor gives users flexible screen view angle which can have the position angle of the screen set between 0 to 110 degrees.

BUILT IN MOUSE & KEYBOARD HOUSING

Built in Mouse & Keyboard housing offers safe house for the wireless mouse and keyboard coming with the unit

OPTIONAL TOUCH SCREEN ABILITY

It also offers touch screen ability as option if users want to free from using a mouse and keyboard.



Overview

The SC17FZD is the Motorised Foldable Monitor designed by SEADA to offer solutions for the Conference room, Office, Hotel, School, Control centre, Institutions, Auditorium and Reception with its elegant, stylish and multi-functional design. The unit can be folded completely flat to the surface of the desk automatically or any degree between 0 to 110 to offer the best screen view angle to users.

The SC17FZD coming with powder coated and anodised finish provides a soft, silky effect and comes in black or silver finish for customers to choose from.

The standalone SC17FZD unit also has the ability to form a large paperless conference room system with more SC17FZD units or other SEADA conference products. This can be achieved by using the SEADA multimedia conference server.

Solutions that work for your meeting and conference room

SC17FZD MOTORISED FOLDABLE MONITORS

From SEADA Conference

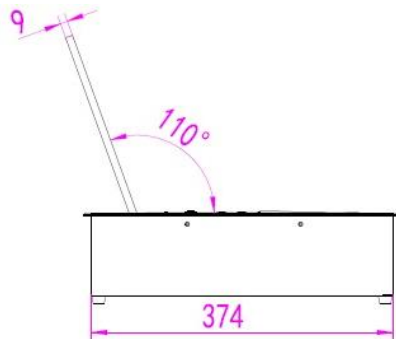
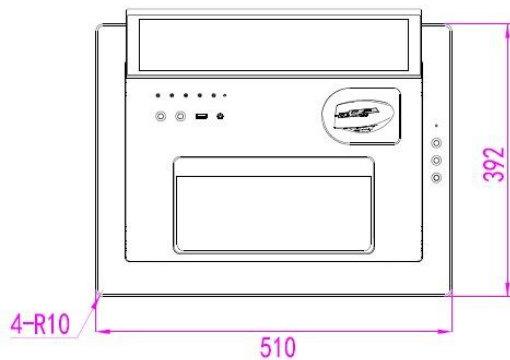
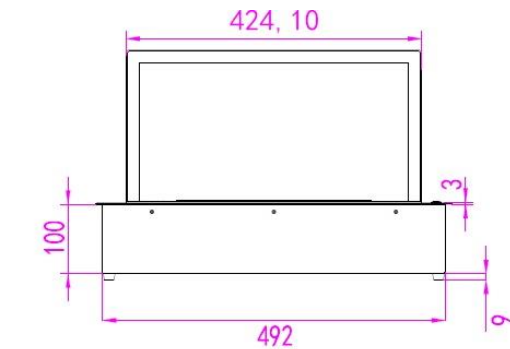

Model	SC17FZD
Screen Position Angle	0-110°
Screen Size (inches)	17.3
Touch Screen	Optional
Frame Finish	Anodised Aluminium
Display Resolution	1920x1080
Monitor Thickness	9mm
System Desktop Frame Size	510mm*392mm*3mm*4-R10
Housing Desktop Cut Size	496mm*378mm
System Weight	16kg
System Height (with feet)	109mm
Video Signal	HDMI/VGA
System Shipping Dimensions	620mm*520mm*210mm
Operating Temperature Range	0~40°
Operating Humidity Range	10%~90% non-condensing
Storage Temperature Range	-20~60°
Storage Temperature Range	10%~90% non-condensing
Parts Warranty	2 Years