

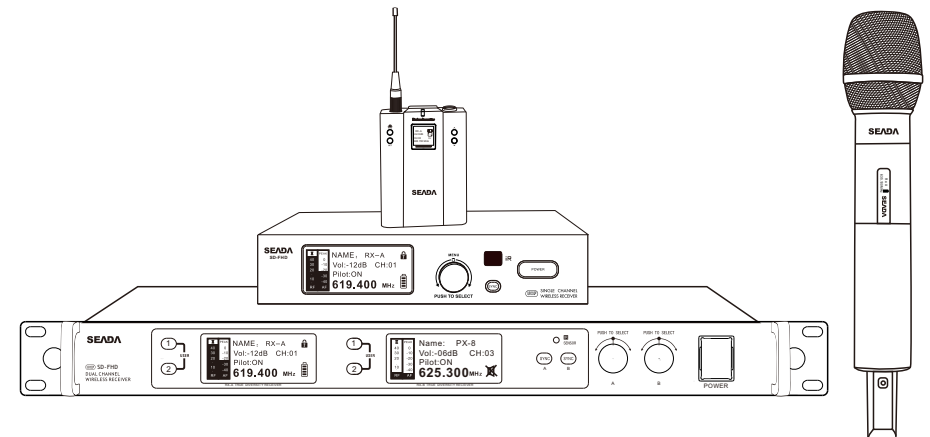













SD-FHS Single Channel Wireless Microphone SD-FHD Dual Channel Wireless Microphone User Guide











CONTENTS

Important safety instructions.....	2
True Diversity Receiver	5
SD-FHS receiver	5
SD-FHD receiver	6
Overview of the displays	7
Overview of the handheld microphone	8
Overview of the bodypack transmitter	9
Using the Receiver	11
Overview of the operating menu	13
Specifications	20
SD-FHS True Diversity Receiver	20
SD-FHD True Diversity Receiver	21
Wideband Handheld Microphone	22
Wideband Bodypack Transmitter.....	23

Important Safety Instructions

-  THE TRIANGLE WITH THE LIGHTNING BOLT IS USED TO ALERT THE USER TO THE RISK OF ELECTRIC SHOCK.
-  THE TRIANGLE WITH THE EXCLAMATION POINT IS USED TO ALERT THE USER TO IMPORTANT OPERATING OR MAINTENANCE INSTRUCTIONS.
-  THE CE-MARK INDICATES THE COMPLIANCE WITH THE LOW VOLTAGE AND ELECTROMAGNETIC COMPATIBILITY.
-  SYMBOL FOR EARTH/GROUND CONNECTION.
-  SYMBOL INDICATING THAT THE EQUIPMENT IS FOR INDOOR USE ONLY.
-  SYMBOL FOR CONFORMITY WITH DIRECTIVE 2012/19/EC OF THE EUROPEAN PARLIAMENT ON WASTE ELECTRICAL AND ELECTRONIC EQUIPMENT (WEEE).
-  DO NOT USE THE UNIT AT ALTITUDES ABOVE 2000 M.
-  DO NOT USE THE UNIT IN TROPICAL ENVIRONMENT.
-  WARNING: TO REDUCE THE RISK OF ELECTRIC SHOCK, DO NOT ATTEMPT TO OPEN ANY PART OF THE UNIT. NO USER-SERVICEABLE PARTS INSIDE. REFER SERVICING TO QUALIFIED SERVICE PERSONNEL.
-  CONNECTION TO THE MAINS SHALL BE DONE ONLY BY A ELECTROTECHNICAL SKILLED PERSON ACCORDING THE NATIONAL REQUIREMENTS OF THE COUNTRIES WHERE THE UNIT IS SOLD.
-  DO NOT USE THIS DEVICE IF THE ELECTRICAL POWER CORD IS FRAYED OR BROKEN.
-  DO NOT SPILL WATER OR OTHER LIQUIDS INTO OR ON THIS DEVICE.

-  NO NAKED FLAME SOURCES SUCH AS LIGHTED CANDLES SHOULD BE PLACED ON THIS DEVICE.
-  WARNING TO PREVENT INJURY, THIS APPARATUS MUST BE SECURELY ATTACHED TO THE FLOOR/WALL IN ACCORDANCE WITH THE INSTALLATION INSTRUCTIONS.
-  THIS DEVICE MUST BE POWERED EXCLUSIVELY BY EARTH CONNECTED MAINS SOCKETS IN ELECTRICAL NETWORKS COMPLIANT TO THE IEC 364 OR SIMILAR RULES
-  DISCONNECT THE AC MAINS SOURCE BEFORE ATTEMPTING TO CLEAN ANY PART OF THIS DEVICE.
-  IT IS HIGHLY RECOMMENDED TO UNPLUG THE OUTPUT CONNECTORS BEFORE PROCEEDING WITH THE SELF CHECK PROCEDURE
-  OUTPUT TERMINALS ARE HAZARDOUS: WIRING CONNECTION TO THESE TERMINALS REQUIRES INSTALLATION BY AN INSTRUCTED PERSON AND THE USE OF READY MADE LEADS.
-  PROPERLY FIT THE AC MAINS PLUG TO THIS DEVICE INLET. BEFORE POWERING THIS DEVICE, VERIFY THAT THE CORRECT VOLTAGE RATING IS BEING USED.
-  VERIFY THAT YOUR MAINS CONNECTION IS CAPABLE OF SATISFYING THE POWER RATINGS OF THE DEVICE.
-  TAKE CARE TO LOCK THE OUTPUT TERMINAL BEFORE SWITCHING THE DEVICE ON.

CLASS3
WIRING



This unit has been engineered and manufactured to ensure your personal safety. But IMPROPER USE CAN RESULT IN POTENTIAL ELECTRICAL SHOCK OR FIRE HAZARD.

In order not to defeat the safeguards incorporated into this product, observe the following basic rules for its installation, use and service. Please read these "Important Safeguards" carefully before use.

- Read these instructions.
- Keep these instructions.
- Heed all warnings.
- Follow all instructions.
- Do not use this equipment near water.
- Clean only with a dry cloth.
- Do not block any ventilation openings. Install in accordance with the manufacturer's instructions.
- Do not install near any heat sources such as radiators, heat registers, stoves, or other apparatus that produce heat.
- Do not defeat the safety purpose of the polarized or grounding-type plug. A polarized plug has two blades with one wider than the other. A grounding-type plug has two blades and a third grounding prong. The wide blade or the third prong are provided for your safety. If the provided plug does not fit into your outlet, consult an electrician for replacement of the obsolete outlet.
- Protect the power cord from being walked on or pinched particularly at plugs, convenience receptacles, and the point where they exit from the apparatus.
- Only use attachments/accessories specified by the manufacturer.
- Use only with the cart, stand, tripod, bracket, or table specified by the manufacturer, or sold with the apparatus. When a cart is used, use caution when moving the cart/apparatus combination to avoid injury from tip-over.
- Unplug this apparatus during lightning storms or when unused for long periods of time.
- Refer all servicing to qualified service personnel. Servicing is required when the apparatus has been damaged in any way, such as power-supply cord or plug is damaged, liquid has been spilled or objects have fallen into the apparatus, the apparatus has been exposed to rain or moisture, does not operate normally, or has been dropped.
- The apparatus shall be connected to a MAINS socket outlet with a protective earthing connection
- Where the MAINS plug or an appropriate coupler is used as the disconnect device, the disconnect device shall remain readily operable.



>> True Diversity Receiver

Features:

- Rugged metal chassis with soft-touch controls.
- Up to 80 simultaneous channels;
- Unique button on each channel of the receiver (SD-FHD) can be used to switch to one more transmitter (either handheld or bodypack transmitter);
- True diversity provides the most effective elimination of dropouts.
- Pilot tone squelch for eliminating RF interference when transmitter is turned off.
- Enhanced AF frequency range
- Built-in spectrum analyzer to auto scan and select a clear channel.
- Transmitter Sync.
- Pure aluminum alloy side plate design (SD-FHD).
- 600 selectable frequencies, 32 preset clean channels
- OLED display screen delivers a bright, clear viewing in day/night environments.
- Equipped with both XLR balanced and Ø6.3mm unbalanced outputs.
- Offers an exceptional value in both performance and price, for both working musicians and sound installers.

SD-FHS receiver

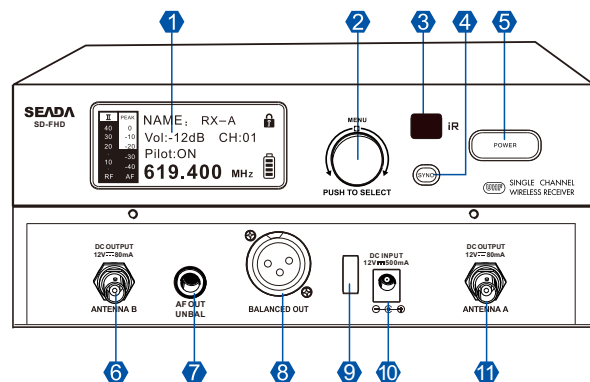

Operating elements – front panel

- 1 Display panel, backlit in orange
- 2 Smart menu-driven knob
- 3 Infra-red interface
- 4 SYNC button
- 5 Power switch

Operating elements – rear panel

- 6 ANTENNA B, BNC socket
- 7 MIXED OUT, unbalanced mixed output jack, 1/4" (6.3mm) jack socket.
- 8 BALANCED OUT, balanced output jack, XLR type connector
- 9 Cable grip for power supply DC cable
- 10 DC Power Output Jack: 12V/500mA.
- 11 ANTENNA A, BNC socket

SD-FHD receiver

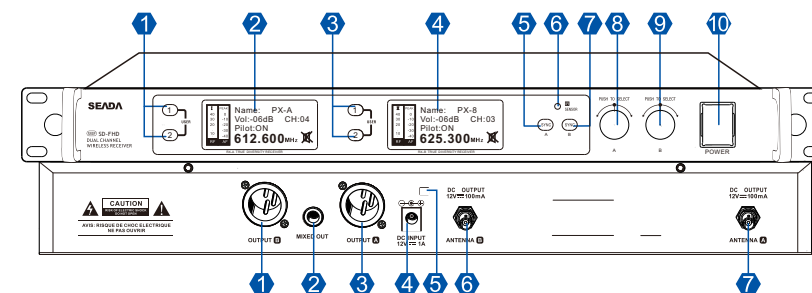

Operating elements – front panel

1. Channel A-Transmitter #1 or Transmitter #2 switching button.
2. Channel A -LCD display panel.
3. Channel B-Transmitter #1 or Transmitter #2 switching button.
4. Channel B-LCD display panel.
5. Channel A-SYNC button.
6. Infra-red interface.
7. Channel B-SYNC button.
8. Channel A-Smart menu-driven knob.
9. Channel B-Smart menu-driven knob.
10. Power switch.



Operating elements – rear panel



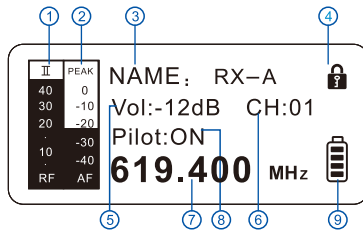

- 1.Channel B - Audio output (AF OUT BAL), XLR-3M socket, balanced
- 2.Mixed output, ¼” (6.3 mm) jack socket, unbalanced
- 3.Channel A - Audio output (AF OUT BAL), XLR-3M socket, balanced
- 4.DC socket (DC IN) for connection of mains unit
- 5.Cable grip for power supply DC cable
- 6.Antenna input B
- 7.Antenna input A

Overview of the displays

After switch-on, the receiver displays the standard display “Receiver Parameters”.



<p>1 RF level “RF” (Radio Frequency)</p>	 <p>True Diversity display I Antenna input I is active II Antenna input II is active RF Singal level: Field strength of the transmitted signal</p>
<p>2 Audio level “AF” (Audio Frequency)</p>	 <p>Modulation of the transmitter with peak hold function. When the level display for audio level show full deflection, the audio input level is excessively high. When the transmitter is over modulated frequently or for extended periods of time, the "PEAK" display is shown inverted.</p>

<p>3 Name</p>	<p>Freely selectable name of the receiver</p>
<p>4 LOCK mode icon</p>	<p>Lock mode is activated</p>
<p>5 Volume</p>	<p>Receiver output volume</p>
<p>6 Frequency bank and Channel</p>	<p>Current frequency bank and channel number, when showing "--" means turning mode.</p>
<p>7 Frequency</p>	<p>Current receiving frequency</p>
<p>8 Pilot tone</p>	<p>Activated pilot tone evaluation(factory preset)</p>
<p>9 Battery status of the transmitter</p>	<p>Battery status:  approx. 100%  approx. 80%  approx. 50%  approx. 10%, changing battery is critical</p>

Overview of the handheld microphone

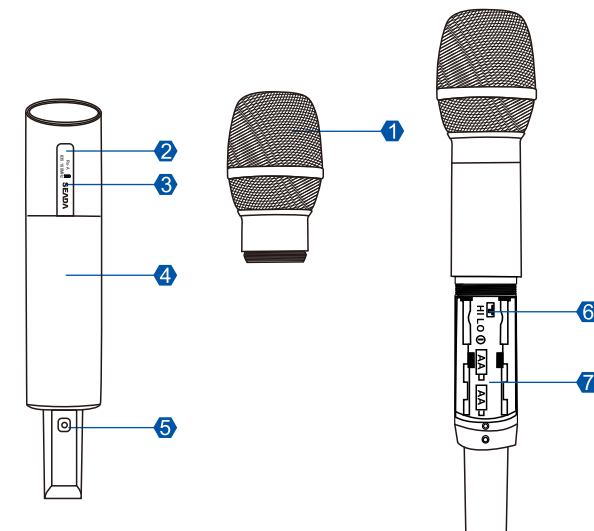

1. **Microphone Head:** The Microphone Head is separate to change other brand microphone head if needed.
 2. **Infrared Data Receiving Window (IR):** Use to receive the data from receiver.
 3. **OLED Window:** OLED display indicates operational frequency, channel, RF Gain and battery life.
- *The transmitter's "fuel gauge" battery indicator displays a maximum of 4 bar segments. When it leaves 1 bar segment the transmitter's batteries should be replaced immediately to ensure continued operation.
4. **Battery Cover:** Unscrew it can reveal the battery compartment.
 5. ① **Power Button**
 - ② When power on, press for mute, again for de-mute.
 - ③ When power on, press 3 times in a row to lock, another 3 times to unlock.
 6. **Gain HI--LO switching**
 7. **Battery compartment:** Insert 2 fresh 1.5 V AA batteries. (Alkaline type is recommended, always replace both batteries.) Observe correct polarity as marked inside the battery compartment.

Overview of the bodypack transmitter

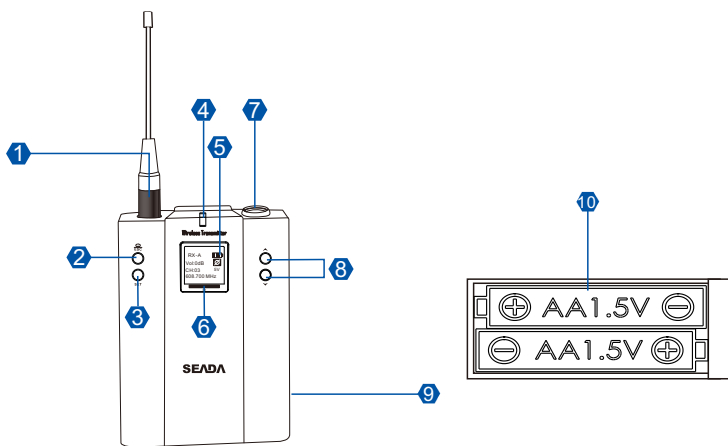

1. **Antenna:** The antenna is separate
2. **Power switch / ESC:**
 - ① Press to turn on the power, when entering edit mode, press this button to ESC. Then press this button for 3 seconds to power off.
 - ② When power on, press for mute, again for de-mute.
 - ③ When power on, press 3 times in a row to lock, another 3 times to unlock.
3. **SET Button:** In conjunction with the ▲ / ▼ button, to step through menus, select and edit function choices.
4. **Power indicator:** Green light when power on, turn red when in low battery.
5. **OLED window:** Display user name, volume, channel, frequency, battery status and phantom power status.
6. **Infrared Data Receiving Window (IR):** Use to receive the data from receiver.
7. **Audio Input Jack:** To connect 4-pin mini-XLR connector
8. **▲ / ▼ Button / MUTE Button:** When power on, press any button to select mute function. Or in conjunction with the SET button, to step through menus, select and edit function choices.
9. **Battery Door Switch:** take out the battery compartment by pressing the switch.
10. **Battery Compartment:** Insert 2 fresh 1.5V AA batteries. (Alkaline type is recommended, always replace both batteries.) Observe correct polarity as marked inside the battery compartment.

Connecting the mains unit

Only use the supplied mains unit. It is designed for the receiver and ensures safe operation.

- > Insert the connector of the mains unit into the socket of the receiver.
- > Pass the cable of the mains unit through the cable grip.
- > Slide the supplied country adapter onto the mains unit.
- > Plug the mains unit into a wall socket.

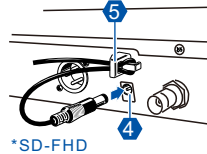

Using the receiver

To establish a transmission link, proceed as follows:

1. Switch the receiver on.
2. Switch the transmitter on. The transmission link is established and the receiver's RF level display "RF" reacts.

If you cannot establish a transmission link between transmitter and receiver:

- > Make sure that transmitter and receiver are set to the same frequency bank and to the same channel.
- > If necessary, read the chapter "If a problem occurs ...".

Deactivating the lock mode temporarily

You can activate or deactivate the automatic lock mode via the "Auto Lock" menu item. If the lock mode is activated, you have to temporarily deactivate it in order to be able to operate the receiver:



Press the menu-driven knob, "unlocked" appears on the display panel.



Rotate the knob to select "Yes"



When you are in the operating menu, the lock mode is deactivated as long as you are in the operating menu.

When one of the standard displays is shown, the lock mode is automatically activated after 10 seconds.

The lock mode icon flashes prior to the lock mode being activated again.

If you need to deactivate "Locked", please enter into the Menu to select "Auto Lock" for OFF.

Scan the frequency banks for clear channels:

- > Switch off all transmitters of your system that are to be automatically configured.
- > Press the knob to select "Freq scan".
- > The device will automatically scan the using frequencies and show the strength the signals.
- > Rotate the knob to see the using frequencies.
- > Press the knob to store a clear frequency.

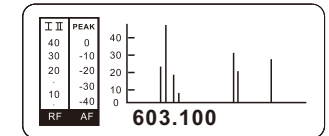

To transfer the parameters:

- > Switch the transmitter and the receiver on.
- > Press the "SYNC" button on the receiver. "Sync" appears on the display panel of the receiver.
- > Place the infra-red interface of the transmitter in front of the infra-red interface of the receiver.
- > The parameters are transferred to the transmitter. When the transfer is completed, "succeed" or "fail" appears on the display panel. The receiver then switches back to the current standard display.

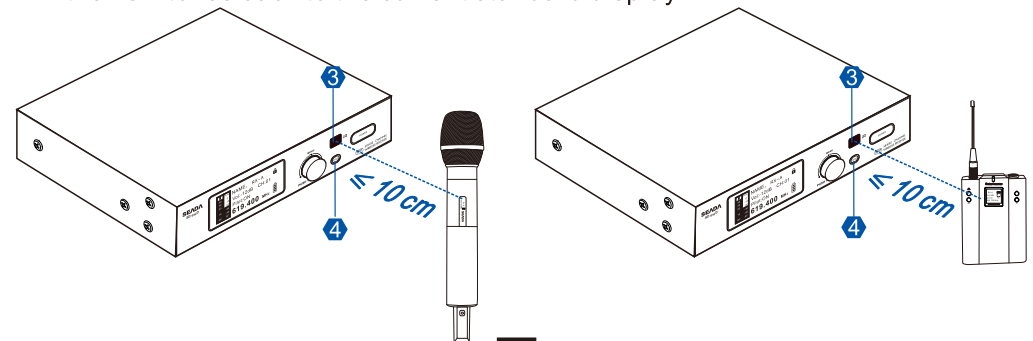

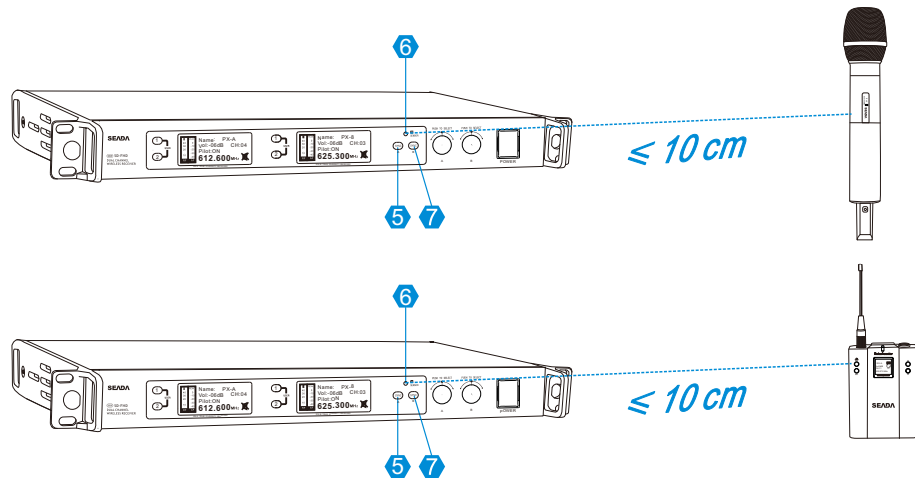

Switch the other transmitter for SD-FHD, do the same setup for Channel B

Using the Receiver operating menu

The buttons

Menu-driven knob	Function of the Knob
Press the knob	<ul style="list-style-type: none"> Enters a submenu Stores the settings and returns to the operating
Rotate left	<ul style="list-style-type: none"> Enters a submenu Stores the settings and returns to the operating menu Selects a standard display Changes to the next/previous menu item Changes the setting of a menu item
Rotate right	<ul style="list-style-type: none"> Selects a standard display Changes to the next/previous menu item Changes the setting of a menu item

Overview of the Receiver operating menu

Channel	Select factory preset 32 channels
Volume	Adjust the volume output level Range : -24 - 18dB
Freq Scan	Scan function for scanning the frequency banks for clear frequency
Squelch	Adjusts the squelch threshold
Name	Enters a freely selectable name
Auto Lock	Activates/deactivates the automatic lock mode
Pilot	Activates/deactivates the pilot tone evaluation
Lang	Language: English / Chinese
Tune Freq	Sets the receiving frequencies manually
Exit	Exits the extended menu and returns to the main menu

Bodypack menu setup

1. Turn on the bodypack, the OLED displays the preset data.

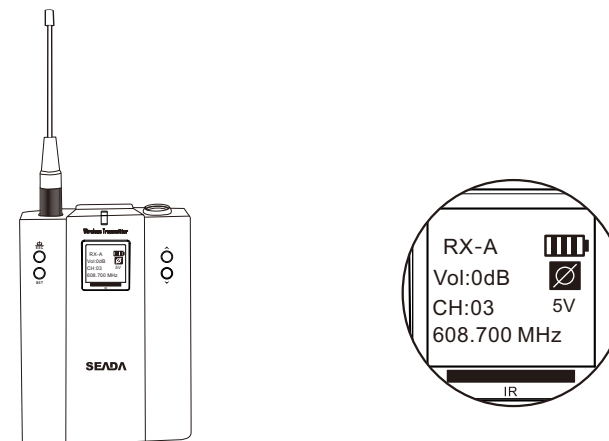

2. Press any ▲ / ▼ Button to choose MUTE function, then press SET button to confirm.

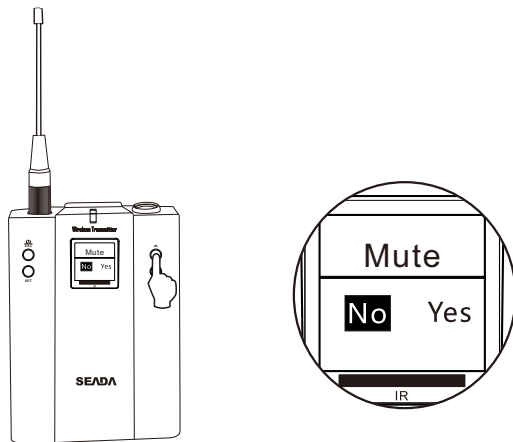

3. To enter the menu mode: Press SET button, in conjunction with the ▲ / ▼ button to enter the edit mode

1) **Volume:** There is range -12dB to 6dB, press ▲ / ▼ to select and SET button to confirm the desired choice, or ESC button to exit.

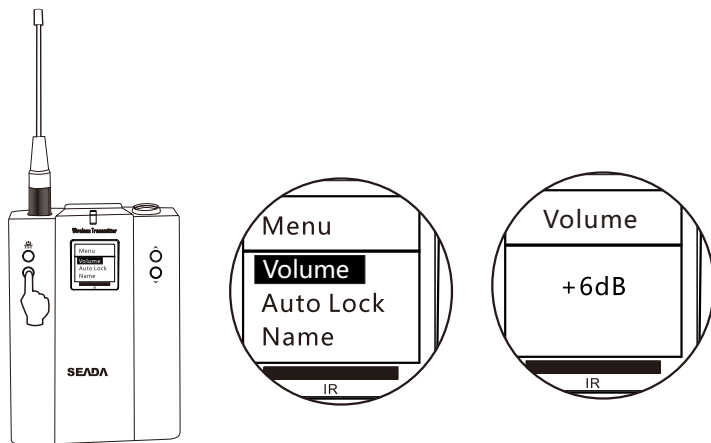

2) **Auto Lock:** Press ▲ / ▼ button to select "Active" or "Inactive", then SET button to confirm the desired choice, or ESC button to exit.

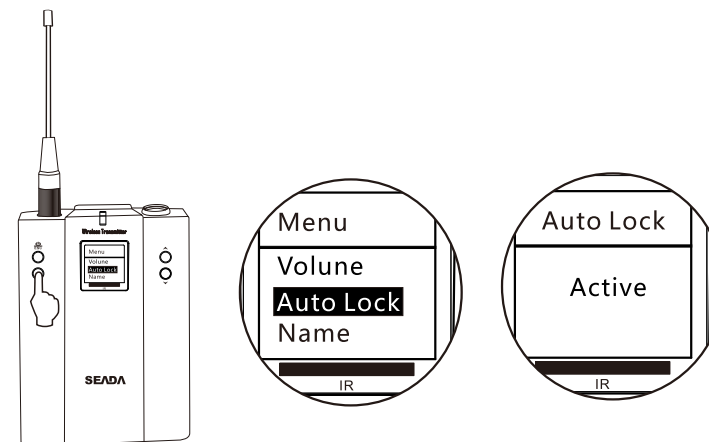

3) **Name:** There are 8 letters to name the bodypack, SET button to confirm the name, then it will be displayed on the OLED window.

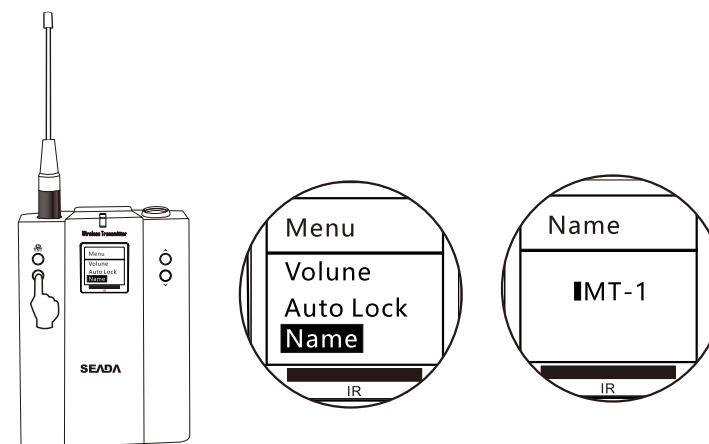

4) **Advanced**: Press SET button to enter edit mode.

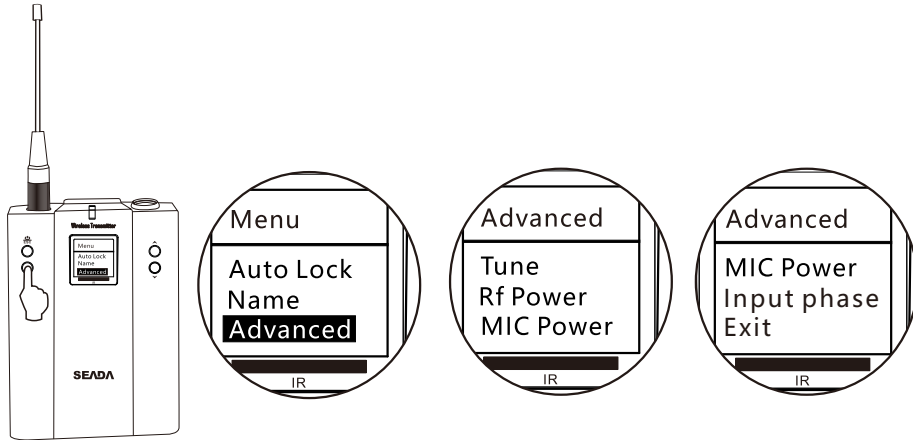

① **Tune**: Setup the frequency manually.

② **Rf Power**: Press ▲ / ▼ button to select “High” or “Low”, then SET button to confirm the desired choice, or ESC button to exit.

③ **MIC Power**: It is providing 5V, 12V and 48V phantom power, SET button to confirm the desired choice, then it will be displayed on the OLED window.

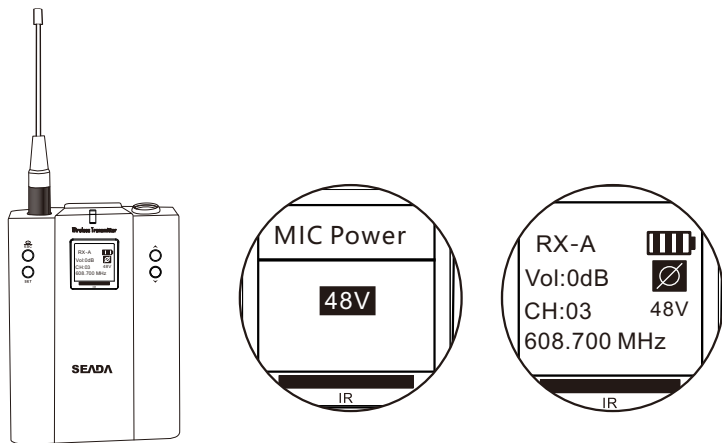

Select 48V phantom power

④ **Input phase**: Select "inverse" or "positive" according to the 4-pin input signal, factory preset "inverse"

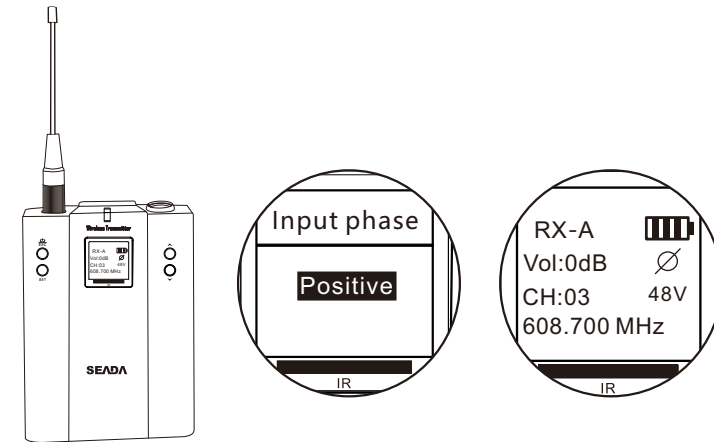
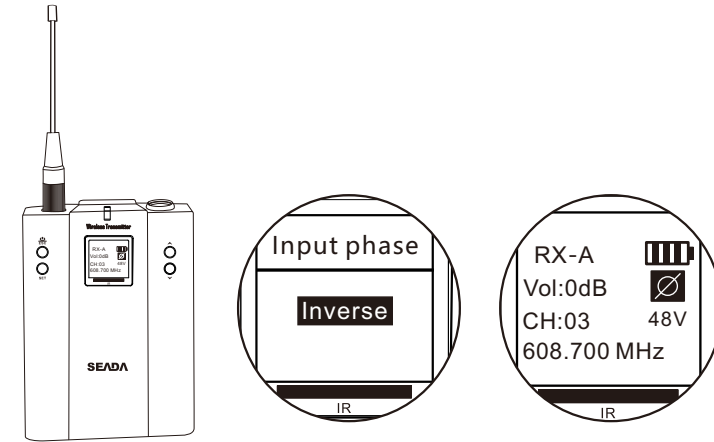

5) **Lang**: Language, there are Chinese / English.

6) **Exit**

If a problem occurs...

Problem	Possible cause	Possible solution
Receiver cannot be operated, "Locked" appears on the display panel	Lock mode is activated	Deactivated the lock mode
No RF signal	Transmitter and receiver are not on the same channel	Set the transmitter and receiver to the same channel. To do so, use the synchronization
	Transmitter is out of range	Reduce the distance between transmitter and receiving antennas
RF signal available, no audio signal, "MUTE" appears on the display panel	Transmitter is muted	Cancel the muting
	Receiver's squelch threshold is adjusted too high	Reduce the squelch threshold or reposition the antennas
Audio signal is distorted	Receiver's audio output level is adjusted too high	Reduce the audio output level
None of the diversity displays I or II appears on the display pane	Antennas are not correctly connected	Check the antenna cables or the antennas and reposition the antennas

If a problem occurs that is not listed in the above table or if the problem cannot be solved with the proposed solutions, please contact our local partner for assistance.

Specifications

SD-FHS True Diversity Receiver

Main Frame Size	EIA-Standard 19" 1/2U
Channels	Single Channel
Frequency Stability	±0.005%, Phase Lock Loop frequency control
Carrier Frequency Range	UHF 603-699 MHz (country dependent)
Preset Channels	32 preset channels
Operating Range	100M typical (in open space)
Oscillation	PLL synthesized
Sensitivity	6dB μ V, S/N>60dB at 25 deviation
Band Width	30MHz
Max. Deviation Range	±45KHz
S/N	>105dB
T.H.D.	<0.7% @ 1KHz
Frequency response	45Hz ~ 18KHz±1dB
Squelch	"PiloTone & NoiseLock" dual-squelch circuit
Power Supply	100-240V AC50/60 Hz, 10W
Weight	720G
Dimension	212 (W) X44 (H) X 202(D)(mm)
Output Connector	XLR balanced & 6.3 ϕ phone jack unbalanced

SD-FHD True Diversity Receiver

Main Frame Size	EIA-Standard 19"
Channels	Dual Channel
Frequency Stability	±0.005%, Phase Lock Loop frequency control
Carrier Frequency Range	UHF 603-699 MHz (country dependent)
Preset Channels	32 preset channels
Operating Range	100M typical (in open space)
Oscillation	PLL synthesized
Sensitivity	6dBμV, S/N>60dB at 25 deviation
Band Width	30MHz
Max. Deviation Range	±45KHz
S/N	>105dB
T.H.D.	<0.7% @ 1KHz
Frequency response	45Hz ~ 18KHz±1dB
Squelch	“PiloTone & NoiseLock” dual-squelch circuit
Power Supply	100-240V AC50/60 Hz, 10W
Weight	2.2KG
Dimension	482 (W) X44 (H) X 185(D) (mm)
Output Connector	XLR balanced & 6.3φ phone jack unbalanced

Wideband Handheld Microphone

Carrier Frequency Range	UHF 603-699 MHz (country dependent)
Oscillation	PLL synthesized
Harmonic radiation	<-65dBm
Bandwidth	120MHz
Max. Deviation Range	±45KHz
Microphone Element	Cardioid Dynamic
RF Power Output	3~30mW (country dependent)
Battery	AA X 2 Alkaline
Current Consumption	90mA, typical
Battery Current / Life	Approximately 10 hours
Dimension	52(Φ) X 264 (L) (mm)
Weight	250g(w/o battery)

Wideband Bodypack Transmitter

Carrier Frequency Range	UHF 603-699 MHz (country dependent)
Oscillation	PLL synthesized
Harmonic radiation	< -63dBm
Bandwidth	120MHz
Max. Deviation Range	±45KHz
Input Connector	4-pin mini-XLR connector
RF Power Output	3~30mW (country dependent)
Battery	AA X 2 Alkaline
Current Consumption	60mA, typical
Battery Current / Life	Approximately 5~10 hours (phantom power selection dependent)
Dimension	63(W) X 80.5(H) X 20.4(D) (mm)
Weight	200g